



**VALVE
CONTROL**



CENTORK. ESPECIALISTS IN VALVE ACTUATION.

With its wide range of actuation products- electric actuators, pneumatic actuators and positioners- Centork covers virtually any need in the actuation and control of valves.

Inheriting the experience acquired during the last 25 years by Centralair and pushed by its dynamic R+D department, Centork has developed valve actuation products, from the standard product to the special product according to the customers high specifications, that are successfully competing in the international market. Centork has the experience, know-how and product range to supply any valve actuation solution.

From a water sewage treatment plant to an offshore oil platform, through a power generation facility, Centork is present to deliver the best customer service anywhere in the world.

Our international partners network ensures a local answer to our customers, from the initial enquiry through to after-sales service, maintenance or retrofitting.

In a world more and more specialized, with the introduction of the new digital technologies, being able to rely on an actuation specialist like Centork is a warranty for the future.

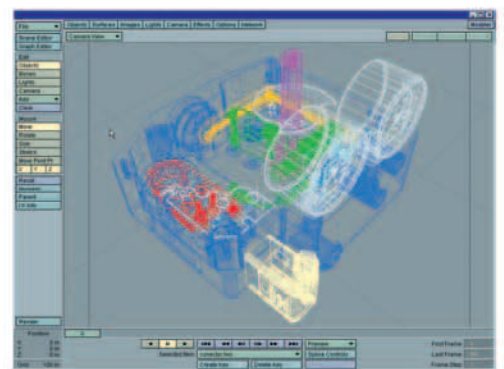
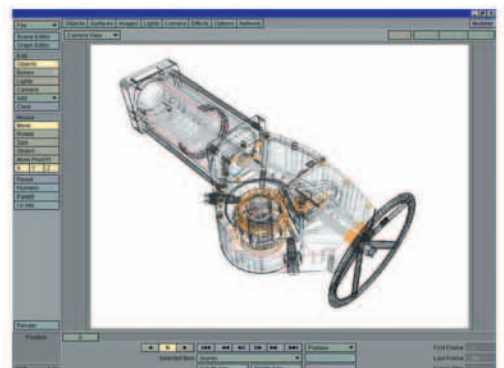
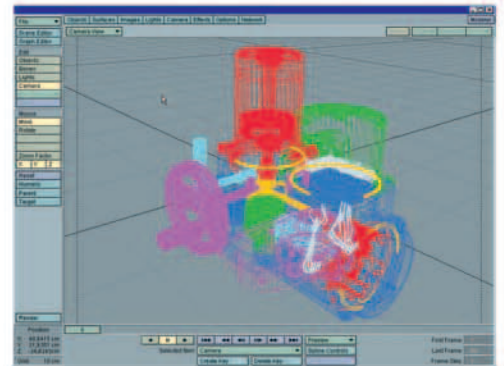

CENTORK. ESPECIALISTS IN VALVE ACTUATION.



ELECTRIC ACTUATORS

MULTITURN

- On-Off: 400/401 Series
- Modulating: 410/411 Series

- Torques from 15 to 4000 Nm



MULTITURN DIGITAL

- On-Off: 460/461 Series
- Modulating: 470/471 Series

- Torques from 15 to 4000 Nm



SPECIAL ACTUATORS

- Hydraulic multiturn actuators
4H0 Series
- Pneumatic multiturn actuators
4P0 Series



G E A R B O X E S

MULTITURN GEARBOXES

- Manual or motorised service
- Couplings according to ISO 5210

- Torques from 120 to 16.000 Nm



ELECTRIC ACTUATORS

QUARTER-TURN

► 480 Series

- Torques from 30 to 1200 Nm



QUARTER-TURN: MULTITURN+WORM GEARBOX

► On-Off: 400-460 Series + CW

► Modulating: 410-470 Series + CW

- Torques from 280 to 350.000 Nm



QUARTER-TURN WITH LEVER

► On-Off: 400-460 Series + FCW

► Modulating: 410-470 Series + FCW

- Torques from 280 to 350.000 Nm



LINEAR

► On-Off: 400-460 Series + LC

► Modulating: 410-470 Series + LC

- Thrust from 7 to 200 KN



G E A R B O X E S

QUARTER-TURN GEARBOXES

► Manual or motorised service

► Special solutions

► Couplings according to ISO 5211

- Torques from 280 to 350.000 Nm



PNEUMATIC ACTUATORS

LINEAR

- On-Off & Modulating
- Single acting and Double acting



- Thrust up to 72 KN



QUARTER-TURN

- On-Off & Modulating
- Single acting and Double acting



- Torques up to 26.000 Nm



SPECIAL SOLUTIONS

- Failsafe
- Custom specifications
- Hydraulic actuators
- Self-contained, Autonomous.



POSITIONERS

LINEAR

Pneumatic, Electropneumatic and Digital

- 120 Series
- 730 Series
- 640 Series



QUARTER-TURN

Pneumatic, Electropneumatic and Digital

- 720 Series



ACCESSORIES

Limit Switchboxes, Position transmitters, Indicators, Solenoid valves and mounting kits.

CONTROL & COMMUNICATION



- Digital communication. Fieldbuses.



- Centronik control unit.



STANDARDS

ATEX
European machine directive CE



- Control cabinets.